

Lemi[®]
ITALIAN WELLNESS EQUIPMENT



GINECOLOGIA

GYNAECCOLOGY



standard version with thigh support / versione standard con reggicose



version with foot support / versione con supporto piede



version with removable legrest / versione con gamba estraibile

COD. 305

Gyno Plus is specifically designed for private clinics and hospital settings for gynecology, ultrasounds, colposcopic examinations, diagnostics and urology. Thanks to its minimum height of 51 cm and very precise adjustment of several positions, it ensures maximum ease of access for the patient and at the same time offers ideal functionality for the doctor. Manual legrest upon request.

Gyno Plus è la poltrona progettata per utilizzo in ambito medico privato e ospedaliero per ginecologia, ecografie, esami colposcopici, visite diagnostiche e urologia. Grazie alla sua altezza minima di 51 cm e alla regolazione molto precisa di più posizioni, garantisce la massima facilità di accesso per il paziente e allo stesso tempo offre la funzionalità ideale per il medico. Gamba manuale disponibile su richiesta.

Focus on

- 3 motors for height, backrest and trendelenburg adjustment
- Foot pedal control
- Automatic reset function
- 90° rotation from both sides
- "Easy-to-clean" mattress without stitches
- Wide selection of class 1IM fire-resistant coverings
- Removable legrest available upon request
- Standard version includes: stainless steel basin for organic waste, thigh support couple, seat guides couple, fixed clamps couple, stainless steel handles and roll holder

- 3 motori per regolazione di altezza, schiena e trendelenburg
- Pedaliera
- Funzione di azzeramento automatico
- Rotazione di 90° da entrambi i lati
- Materasso senza cuciture "easy-to-clean"
- Ampia scelta di rivestimenti ignifughi classe 1 IM
- Gamba estraibile disponibile su richiesta
- La versione standard include: vaschetta in acciaio inossidabile per rifiuti organici, coppia di reggicose, coppia guide seduta, coppia morsetti fissi, maniglie in acciaio inossidabile e porta rotolo

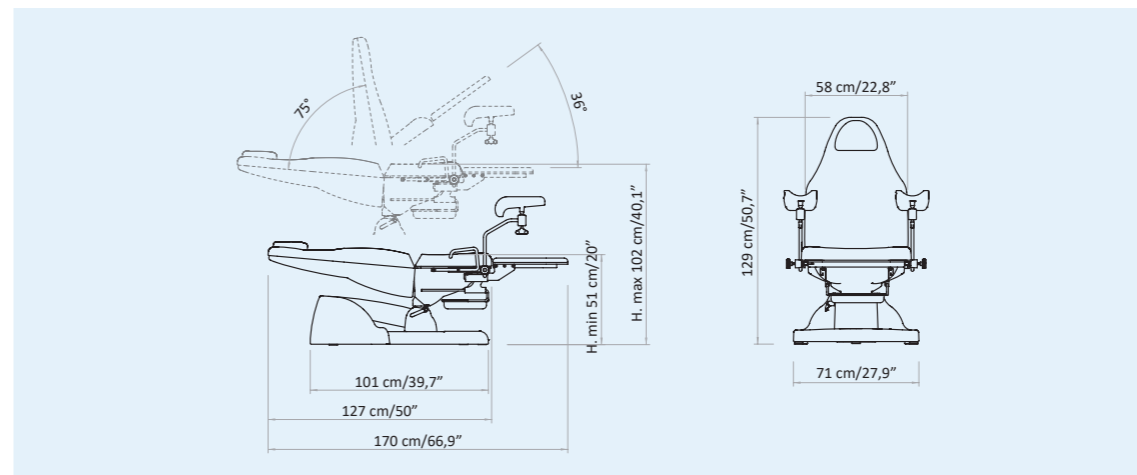

Packaging details

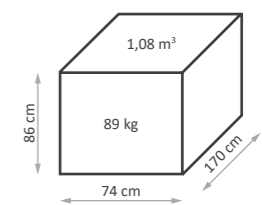

MAXIMUM CAPACITY PORTATA MASSIMA
200 kg

MOVEMENTS

3 independent electric movements: height, backrest and trendelenburg
Extractable legrest
Automatic reset control to bring the chair back to the initial position
180° Chair rotation

MOVIMENTI

3 movimenti elettrici indipendenti: altezza, schiena e trendelenburg
Gamba estraibile
Comando di azzeramento automatico che riporta la poltrona nella posizione base
Rotazione poltrona 180°



Easy-to-clean anatomic mattress without stitching
Materasso anatomico senza cuciture per una facile igienizzazione

51-102 cm
(20" - 40")



Electric height
Altezza elettrica



36°

Electric Trendelenburg
Trendelenburg elettrico

90° rotation on both sides
Rotazione 90° da entrambi i lati

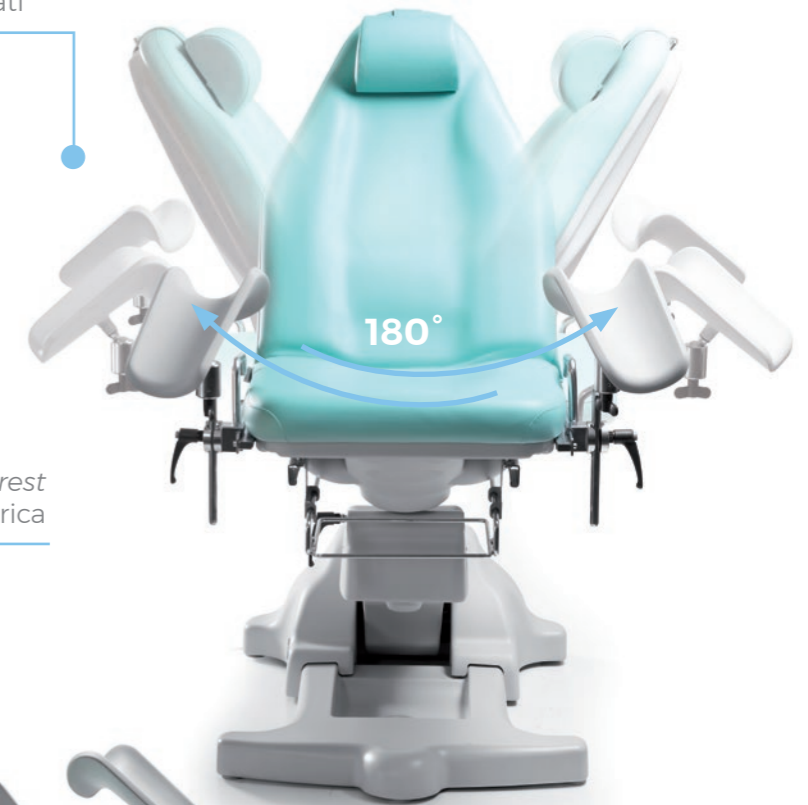

180°

75°

Electric backrest
Schiena elettrica



Large Removable stainless steel bowl, for collecting organic waste - 27 x 33 x 5 h cm - 10,6" x 12,9" x 1,9" h

Ampia bacinella in acciaio inox estraibile, per la raccolta dei rifiuti organici - 27 x 33 x 5 h cm - 10,6" x 12,9" x 1,9" h



BASE CUSTOMIZATION

We provide a thermoformed ABS base, completely closed to prevent any infiltration of powders or liquids. It is a very hard material, scratch-proof resistant and easy-to-clean.

PERSONALIZZAZIONE BASE

Forniamo una base in ABS termoformato, completamente chiuso per evitare qualsiasi infiltrazione di polveri o liquidi. È un materiale molto duro, resistente ai graffi e facile da pulire.

MATTRESS CUSTOMIZATION

Nefos is the exclusive upholstery line by Lemi. The innovative material and its special finishing touch guarantee easy-cleaning and hygiene. Its extraordinary structural qualities will persist through the years. An incredibly elastic texture enhances the memory foam mattress softness and quality at its best.

PERSONALIZZAZIONE MATERASSO

Nefos è la linea di rivestimento esclusive di Lemi. L'innovativo materiale e il suo speciale tocco di finitura garantiscono una facile pulizia e igiene. Le sue straordinarie qualità strutturali permangono nel corso degli anni. Una texture incredibilmente elastica migliora al massimo la morbidezza e la qualità del materasso in Memory Foam.

Available finishing for GYNO PLUS 305 + 318
Finiture disponibili per GYNO PLUS 305 + 318



White
Bianco



Grey
Grigio

NEFOS COLORS

COLORI NEFOS



The images are for illustrative purposes only and may not reflect the actual finish of the product, particularly when viewed through a screen. Therefore, the **SELECTION OF THE MATTRESS FABRICS** must take place **AFTER CONSULTING** the **PHYSICAL SAMPLES** in the **NEFOS COLOR CHART**.



Le immagini hanno valore puramente illustrativo e possono non rispecchiare la finitura reale del prodotto, in particolare se visualizzate attraverso uno schermo. Pertanto la **SELEZIONE DEI RIVESTIMENTI DEI MATERASSI** deve avvenire **PREVIA CONSULTAZIONE** della **CAMPIONATURA FISICA** nella **CARTELLA COLORI NEFOS**.

ACCESSORIES UPON REQUEST ACCESSORI SU RICHIESTA

All Medical chairs have a standard setting customizable upon request.

Tutte le poltrone Medicali hanno una configurazione standard personalizzabile su richiesta.



Wireless foot pedal control
(NO foot pedal with cable NO remote control)
Pedaliera wireless (NON compatibile con il pedale a filo e con la pulsantiera)



Foot support couple
Coppia supporto piedi



Handset control
Pulsantiera



Back guide couple
Coppia guide schiena



I.V. Rod
(fixed with rotatable clamp and guides on the back)
Asta portaflebo
(da fissare con morsetto girevole e guide schiena)



Colposcope support
Supporto colposcopio



Fixed clamp
Morsetto fisso



Wheels with brake (ø 50mm)
Ruote con freno (ø 50mm)



Rotatable clamp
Morsetto girevole



GYNO Lamp
Lampada GYNO



Medical armrest couple (to be fixed with rotatable clamp and guides on the back)
Coppia braccioli medicali
(da fissare con morsetti girevoli e guide schiena)



Inox tray with support (fixed with fix clamp and guides on the seat)
Vassoio inox completo di telaio (da fissare con morsetto fisso e guide seduta)



Blood sample taking armrest couple (fixed with fix clamp and guides on the seat)
Coppia braccioli da prelievo con snodo (da fissare con morsetto fisso e guide seduta)



Plastic protection for head support
Protezione in plastica per poggiatesta

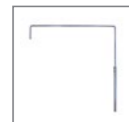

Curtain holder
(fixed with rotatable clamp and guides on the back)
Reggitelo
(da fissare con morsetto girevole e guide schiena)



UK cable
Cavo UK



Leg support
Supporto gamba



USA cable
Cavo USA



Flat automatic armrest couple
Coppia braccioli automatici



Customization with logo
Personalizzazione con logo

TECHNICAL REQUIREMENTS

CARATTERISTICHE TECNICHE

ELECTRIC REQUIREMENTS / CARATTERISTICHE ELETTRICHE

VOLTAGE VOLTAGGIO	FREQUENCY FREQUENZA	ABSORPTION ASSORBIMENTO	TRANSFORMER TRASFORMATORE	PROTECTION RATING GRADO DI PROTEZIONE	ELECTRIC SYSTEM CONFORMS TO CEI NORMS IMPIANTO ELETTRICO a norme CEI	CONTROL BOX CENTRALINA
230/110V ac	50/60 Hz	0,7 - 1 A max	120 Va	IP 54	4	class II classe II

TECHNICAL SPECIFICATION / SPECIFICHE TECNICHE

MINIMUM HEIGHT: 51 CM / 20"

MAXIMUM HEIGHT: 102 CM / 40"

ANGLE OF INCLINATION TRENDELENBURG: 36°

ANGLE OF INCLINATION BACK REST: 75°

MATTRESS LENGTH: 127 CM / 50"

MATTRESS LENGTH WITH LEGREST: 170 CM / 67"

MATTRESS WIDTH: 58 CM / 23"

ROTATION: 180°

LATEX-FREE, NON-TOXIC AND NON-CARCINOGENIC MATERIALS

FIRE-RESISTANT UPHOLSTERY: UNI 9175 CLASS I M

ALTEZZA MINIMA: 51 CM / 20"

ALTEZZA MASSIMA: 102 CM / 40"

ANGOLO INCLINAZIONE TRENDELENBURG: 36°

ANGOLO INCLINAZIONE SCHIENA: 75°

LUNGHEZZA MATERASSO: 127 CM

LUNGHEZZA MATERASSO GAMBE ESTESE: 170 CM

LARGHEZZA MATERASSO: 58 CM

ROTAZIONE: 180°

MATERIALI PRIVI DI LATTICE, ATOSSICI E NON CANCEROGENI

RIVESTIMENTO IGNIFUGO: UNI 9175 CLASS I M

WARRANTY / GARANZIA

STRUCTURE: 10 YEARS

MOTORS AND CONTROL: 2 YEARS

CUSHION: 5 YEARS

STRUTTURA: 10 ANNI

MOTORI E CONTROLLI: 2 ANNI

MATERASSO: 5 ANNI

LEMI MATTRESSES

The MATTRESSES of the LEMI GYNO line are made with the best quality materials to ensure maximum comfort for both the patient and the doctor.

MATERASSI LEMI

I MATERASSI della linea GINECOLOGICA LEMI sono realizzati con materiali della migliore qualità per garantire il massimo comfort sia per il paziente che per il medico.



GYNO PLUS

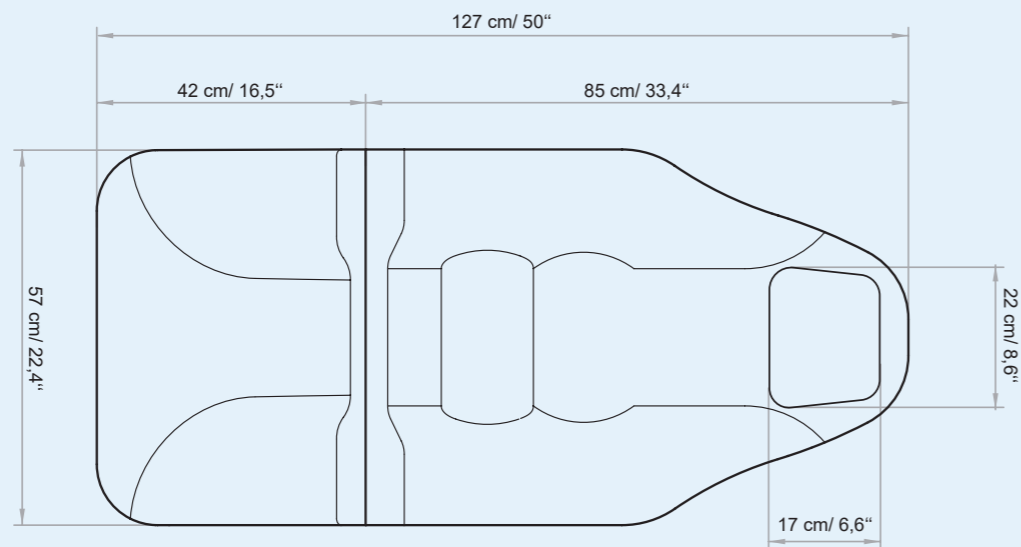

GYNO

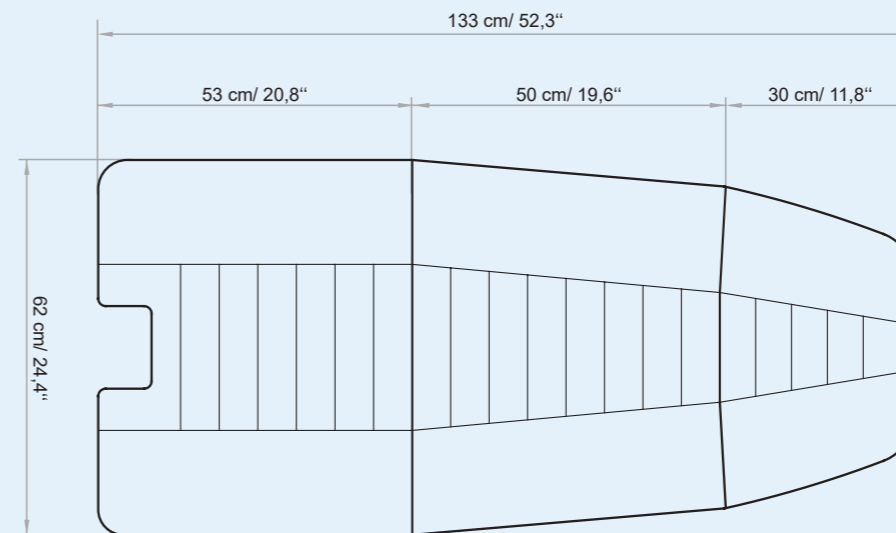

FOOT SUPPORT

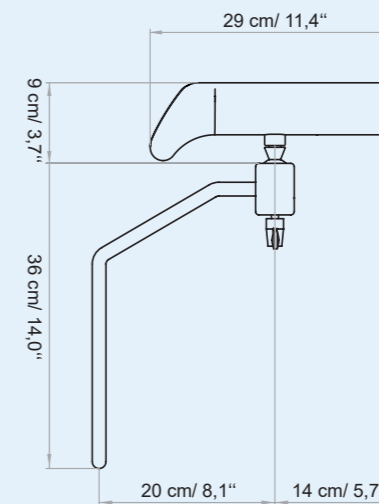
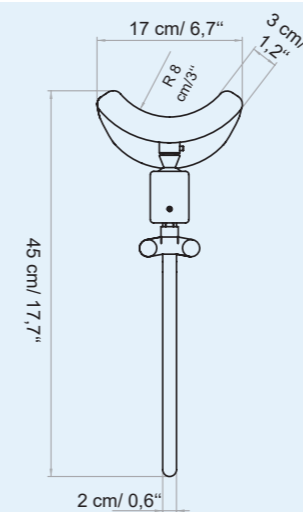
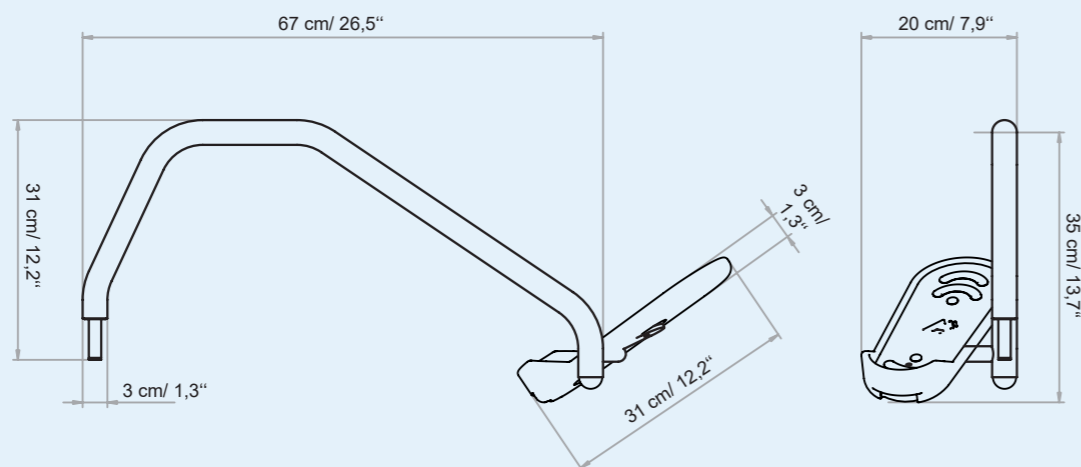

THIGH SUPPORT



REGULATIONS

All Equipment is  marked

Electrical equipment and beds

Directive 2006/42/CE (Machinery Directive) and national regulations
Directive 2014/30/UE (Electromagnetic Compatibility Directive) and national regulations.

Hydraulic equipment and beds

Directive 2006/42/CE (Machinery Directive) and national regulations

Images

The images are for illustrative purposes only and may not reflect the actual image of the product.

NORME

Tutte le attrezzature sono a marchio 

Attrezzature e lettini elettrici

Direttiva 2006/42/CE (Direttiva Macchine) e disposizioni nazionali di attuazione
Direttiva 2014/30/UE (Direttiva Compatibilità elettromagnetica) e disposizioni nazionali di attuazione.

Attrezzature e lettini idraulici

Direttiva 2006/42/CE (Direttiva Macchine) e disposizioni nazionali di attuazione

Immagini

Le immagini hanno valore puramente illustrativo e possono non rispecchiare l'immagine reale del prodotto.

Lemi[®]
ITALIAN WELLNESS EQUIPMENT

Brusaferrì & C srl

Via Mara Maretti Soldi, 13
26011 Casalbuttano (CREMONA) ITALY
Phone +39-0374-363069 Fax +39-0374-363071
info@lemigroup.it service@lemigroup.it

www.lemigroup.it